

REMATRACK UT AND REMATRACK OT

The REMATRACK – tracking units serve continuous belt guiding and correction of the belt run. REMATRACK units ensure that a conveyor belt always is centred in the middle so that damage to the conveyor belt and its protective edges is prevented.

BELT TRACKING UNIT

REMATRACK UT and REMATRACK OT

Type REMATRACK UT is designed for the return belt
Type REMATRACK OT is designed for the carrying belt

- Highly robust steel structure
- The base frame can be continuously extended
- Clamping devices on both sides allow a highly accurate setting of the REMATRACK
- The central rotational axle is provided with 2 Z bearings and double sealing in order to guarantee lasting full function of the rotation
- Relubrication of the bearings is not required
- The rotation of the idler roller carrier is limited to +/- 30° by design
- The idler rollers used are made by special production and are provided with highly robust Z bearings and shaft sealing - steel casing thickness 6 mm
- In the OT type, the idler rollers have 4 Z bearings each to that they can lastingly carry the highest load
- Idler rollers are coated with abrasion-proof PUR using the hot-moulding process in order to ensure an especially long service life and achieve a 100% connection of the casing with the PUR
- Idler rollers are secured against falling out
- Available for the belt widths: 500 – 1,400 mm
- Application up to speeds of 4.5 m/s

Fields of application:

- REMATRACK stations are suited for all belt systems where wrong loading, deposits on the idler rollers or wind may cause a misalignment of the belt
- For standard applications, there are used the red idler rollers of polyurethane
- Special version: Applications with chemically active materials, much water or products containing oil - for these applications, idler rollers with a white lining and carriers, axles of stainless steel are used
- Also suitable for conveyor belts in reversing operation

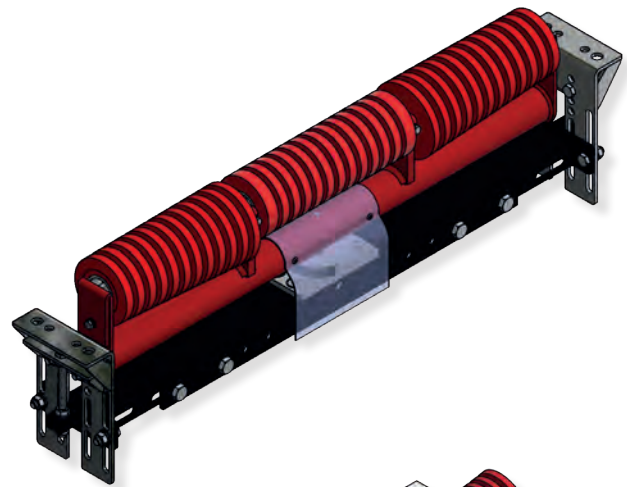

REMATRACK UT

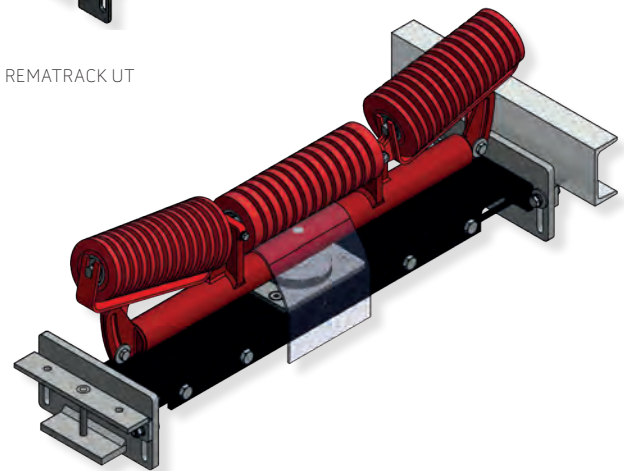

REMATRACK OT



TRAGROLLEN MIDDLE

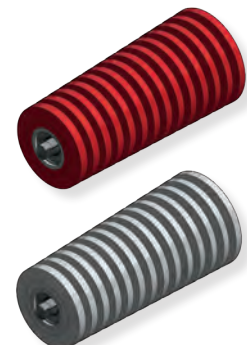

TRAGROLLEN SIDE



REMA TIP TOP AG
Gruber Strasse 65 · 85586 Poing / Germany
Phone: +49 8121 707-100
Fax: +49 8121 707-10 222
info@tiptop.de
www.rema-tiptop.com

Your local contact